

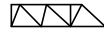



SK1700

 20 m —  65 m

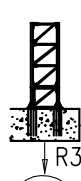
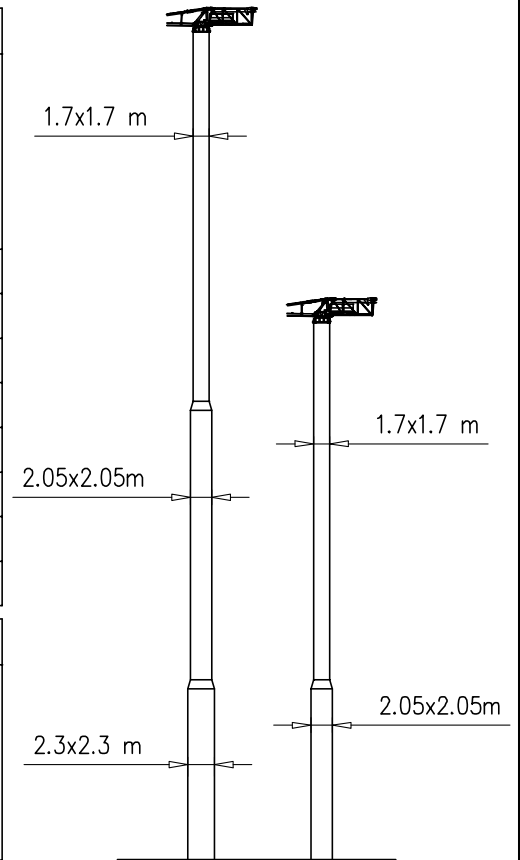

Torre/Masts/Mat/Maste/Măstil/Tramo															
	H[m]	4f/4f BF117	4f/4f BF052	4f/4f BF039	4f/2f SB117	4f/2f SB052	4f/2f SB039	2f/2f ST117	2f/2f ST052	2f/2f ST039	2f/2f STB117	2f/2f STB039	2f/2f RA039	4f/2f SBB039	4f/2f SBB117
TRO 	55.9	2			1			1	1	1					
	52	1			1			2	1						
TTD 	52		3			1			6						
	46.8	1			1			2							
	35.10							3							
	55.9	2			1			1	1	1					
	* 55.9		4										7	1	1
	* 50.7	1											6	1	1



Torre/Masts/Mat/Maste/Măstil/Tramo															
	H[m]	4f/4f BF117	4f/4f BF052	4f/4f BF039	4f/2f SB117	4f/2f SB052	4f/2f SB039	2f/2f ST117	2f/2f ST052	2f/2f ST039	2f/2f STB117	2f/2f STB039	2f/2f RA039	4f/2f SBB039	4f/2f SBB117
CAF 	55.9	1				1		2	2						
	57.2	1	1		1			1	1						
	57.2		4			1			5						
CAF 	52	1			1			2							
	40.3				1			2							
	32.8			1				2							
	* 55.9		3										7	1	1
	* 55.9	1											6	1	1

H=0–37 m		H=38–58 m	
R1	95 t	R1	117 t
R2	102 t	R2	122 t
R3	75 t	R3	89 t
M	295 tm	M	347 tm

Peso zavorra—Ballast weight—  
Ballastgewicht—Peso de lastre

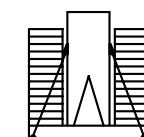

Torre/Masts/Mat/Maste/Măstil/Tramo															
	H[m]	4f/4f BF117	4f/4f BF052	4f/4f BF039	4f/2f SB117	4f/2f SB052	4f/2f SB039	2f/2f ST117	2f/2f ST052	2f/2f ST039	2f/2f STB117	2f/2f STB039	2f/2f RA039	4f/2f SBB039	4f/2f SBB117
CATR 	50.7	1				1		2	1						
	52	1			1			2							
	52		3			1			5						
CATC 	33.8		1		1			1							
	40.3				1			2							
* * 52			3					2							
	* 52	1											7	1	
* 52	1											5	1	1	

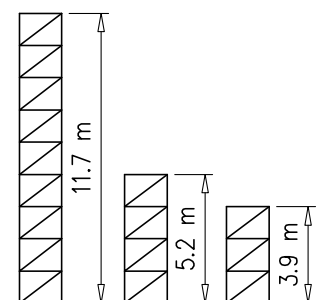
	H	Tot.
	0–40 m	70600 kg
	40–58 m	105600 kg





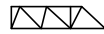

Torre/Reazioni – Masts/Reactions – Mat/Réactions – Maste/Eckdrücke – Mästil/Reacciones – Tramo/Reacções

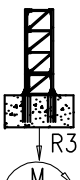
SN2050

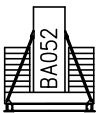
 20 m —  65 m

Torre/Masts/Mat/Maste/Mästil/Tramo															
	H[m]	4f/4f BF117	4f/4f BF052	4f/4f BF039	4f/2f SB117	4f/2f SB052	4f/2f SB039	2f/2f ST117	2f/2f ST052	2f/2f ST039	2f/2f STB117	2f/2f STB039	2f/2f RA039	4f/2f SBB039	4f/2f SBB117
TRO 	63.7	1	1		1			3							
	62.4		4			1			7						
TTD 	35.1				1			2							
	41.6		1	1	1				4						
	48.1	1	1				1	2		1					
	62.4	2										6	1		1
	63.7		4									9	1	1	
	63.7	1	1								8	1		1	

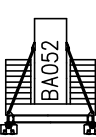
Torre/Masts/Mat/Maste/Mästil/Tramo															
	H[m]	4f/4f BF117	4f/4f BF052	4f/4f BF039	4f/2f SB117	4f/2f SB052	4f/2f SB039	2f/2f ST117	2f/2f ST052	2f/2f ST039	2f/2f STB117	2f/2f STB039	2f/2f RA039	4f/2f SBB039	4f/2f SBB117
	68.9	1	1		1		1	3		11					
	67.6		4			1			7						
	40.3				1			2							
CAF 	46.8		1	1	1				4						
	53.3	1	1				1	2							
	* 67.6	2										6	1		1
	* 68.9		4									9	1	1	
	* 68.9	1	1									8	1		1

Torre/Masts/Mat/Maste/Mästil/Tramo															
	H[m]	4f/4f BF117	4f/4f BF052	4f/4f BF039	4f/2f SB117	4f/2f SB052	4f/2f SB039	2f/2f ST117	2f/2f ST052	2f/2f ST039	2f/2f STB117	2f/2f STB039	2f/2f RA039	4f/2f SBB039	4f/2f SBB117
	50.7	1				1		2	1						
	61.1	1	1		1			2		1					
	62.4		4			1			6						
CATR CATC 	33.8					1		2							
	59.8	2			1			1		2					
	* 61.1		4									7	1	1	
	* 61.1	1	1									7	1		1
	* 61.1	1	1									8	1	1	

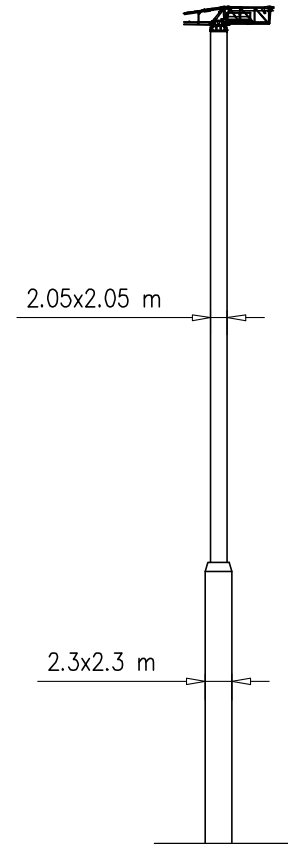

H=0–45 m		H=46–69 m	
R1	125 t	R1	140 t
R2	130 t	R2	144 t
R3	95 t	R3	103 t
M	486 tm	M	570 tm





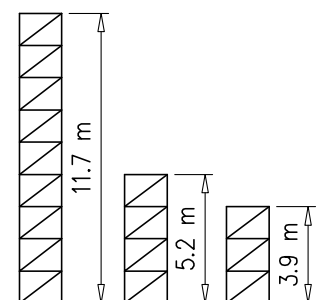





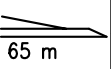

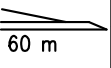

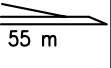

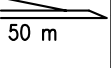

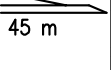
Peso zavorra—Ballast weight—  
Ballastgewicht—Peso de lastre

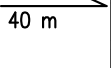
H	Tot.
0–41 m	71900 kg
42–55 m	102320 kg
56–69 m	112460 kg

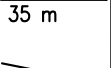

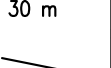

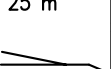

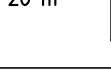



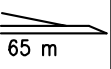

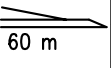

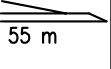

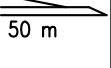

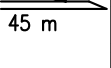

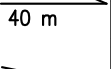
Curve di carico – Courbes de charges – Load diagrams – LastKurven – Curvas de cargas

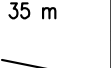
Pmax 3000 kg

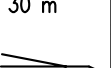
	20400 kg		2.5	36.6	40	45	50	55	60	65	m
			3000	3000	2410	2090	1830	1620	1450	1300	kg
	19200 kg		2.5	37.5	40	45	50	55	60	m	
			3000	3000	2780	2160	1890	1680	1500	kg	
	19200 kg		2.5	39.7	40	45	50	55	m		
			3000	3000	2970	2310	2030	1800	kg		
	18000 kg		2.5	42.4	45	50	m				
			3000	3000	2500	2200	kg				
	16800 kg		2.5	41.8	45	m					
			3000	3000	2750	kg					
	15600 kg		2.5	40	m						
			3000	3000	kg						
	14400 kg		2.5	35	m						
			3000	3000	kg						
	13200 kg		2.5	30	m						
			3000	3000	kg						
	10800 kg		2.5	25	m						
			3000	3000	kg						
	7200 kg		2.5	20	m						
			3000	3000	kg						

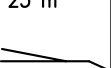

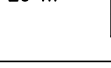









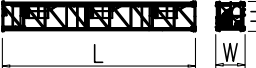

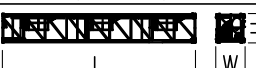
Pmax 6000/3000 kg

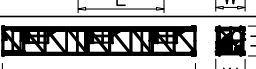
	20400 kg		2.5	19.7	20	25	30	35	36.6	40	45	50	55	60	65	m
			6000	6000	5910	4620	3770	3160	3000	2410	2090	1830	1620	1450	1300	kg
	19200 kg		2.5	20.2	25	30	35	37.5	40	45	50	55	60	m		
			6000	6000	4750	3880	3250	3000	2780	2160	1890	1680	1500	kg		
	19200 kg		2.5	21.4	25	30	35	39.7	40	45	50	55	m			
			6000	6000	5060	4130	3470	3000	2970	2310	2030	1800	kg			
	18000 kg		2.5	23	25	30	35	40	42.4	45	50	m				
			6000	6000	5450	4450	3750	3210	3000	2500	2200	kg				
	16800 kg		2.5	22.5	25	30	35	40	41.8	45	m					
			6000	6000	5350	4380	3680	3160	3000	2750	kg					
	15600 kg		2.5	24	25	30	35	40	m							
			6000	6000	5740	4700	3960	3400	kg							
	14400 kg		2.5	24.2	25	30	35	m								
			6000	6000	5800	4750	4000	kg								
	13200 kg		2.5	26.8	30	m										
			6000	6000	5300	kg										
	10800 kg		2.5	25	m											
			6000	6000	kg											
	7200 kg		2.5	20	m											
			6000	6000	kg											

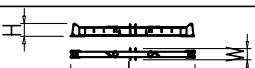
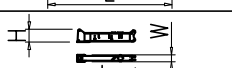
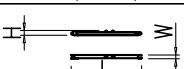
PESI E INGOMBRI – PACKING LIST – LISTE DE COLISAGE – GEWICHT UND ABMESSUNGEN

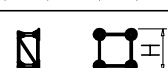
Denominazione Description	Disegno Draw	Pezzi Pieces	Dimensioni-Dimensions (mm)			Peso-Weight (kg)			
			L	W	H	Unit	Total		
Elemento di braccio Jib element Elément de èche Elemento de flecha	n°13		1	5500	1480	2290	2000	–	
	n°12		1	5280	1200	2170	1400	–	
	n°11		1	5270	1200	2150	1150	–	
	n°10		1	5260	1200	2150	900	–	
	n°9		1	5260	1200	2120	800	–	
	n°8		1	5240	1200	2100	700	–	
	n°7		1	5225	1200	2060	635	–	
	n°6		1	5200	1200	1630	500	–	
	n°5		1	5160	1200	1630	370	–	
	n°4		1	5140	1200	1610	350	–	
	n°3		1	5110	1200	1610	250	–	
	n°2		1	5090	1200	1260	210	–	
	n°1		1	5090	1200	1260	200	–	
	Punta braccio		1	700	1200	500	55	–	
Contorbraccio completo Complete counterjib Contreflèche complète Contraflecha completa		1	12560	1810	1480	5130	–		
Gruppo girevole Slewing group Table tournante Grupo giratorio	SK1700		1	2300	1810	2900	5900	–	
	SN2050		1	2450	1810	2900	6200	–	
Carrello Trolley Chariot Carretilla	P6		1	1600	1620	710	320	–	
Ballatoio con cabina Access balcony with cabin Porte cabine Balcòn corrido con cabina			1	2500	2150	2450	1000	–	
Blocchi contrappeso Counterweight block Contre-poids Bloques de contrapeso	VX24 VS12		VS12	1	1000	200	2500	1200	1200
			VX24	8	1000	400	2500	2400	19200

PESI E INGOMBRI – PACKING LIST – LISTE DE COLISAGE – GEWICHT UND ABMESSUNGEN

Denominazione Description	Disegno Draw	Pezzi Pieces	Dimensioni-Dimensions (mm)			Peso-Weight (kg)		
			L	W	H	Unit	Total	
Elemento di torre Mast element Elément de mât Elemento de torre	 STD039	SK1700	–	3900	1785	1785	1750	–
		SN2050	–	3900	2110	2110	2320	–
	 STD052	SK1700	–	5200	1785	1785	2250	–
		SN2050	–	5200	2110	2110	2850	–
	 STD117	SK1700	–	11700	1785	1785	4690	–
		SN2050	–	11700	2110	2110	5790	–
	 SB039	SK1700	–	3900	1785	1785	2100	–
		SN2050	–	3900	2110	2110	2710	–
	 SB052	SK1700	–	5200	1785	1785	2600	–
		SN2050	–	5200	2110	2110	3350	–
 SB117	SK1700	–	11700	1785	1785	4830	–	
	SN2050	–	11700	2110	2110	7000	–	
 BF039	SK1700	–	3900	1785	1785	2450	–	
	SN2050	–	3900	2110	2110	3370	–	
 BF052	SK1700	–	5200	1785	1785	3390	–	
	SN2050	–	5200	2110	2110	3880	–	
 BF117	SK1700	–	11700	1785	1785	6920	–	
	SN2050	–	11700	2110	2110	8180	–	
Elemento di base Base element Mat de base Elemento de base	 BA052	SK1700	1	5200	2060	2060	3650	–
		SN2050	1	5200	2260	2260	4040	–
Carro di base Base carriage Chassis de base Cruceta de base		5x5	1	7550	670	780	2300	2300
		6x6	1	8870	670	780	2500	2500
		5x5	2	3530	420	780	1060	2120
		6x6	2	4320	420	780	1200	2400
Puntoni di base Rafter Jambes de force Cabrios de base		5x5	4	4250	240	300	280	1120
		6x6	4	4560	420	300	420	1680
Elemento a perdere Disposable frame Chassis a perdre Bastidor desechable		SK1700	1	1840	1910	1910	1430	–
		SN2050	1	2600	2260	2260	2030	–
Elemento recuperabile Recoverable frame Chassis récupérable Bastidor recuperable		SK1700	1	1300	2170	2170	1720	–
		SN2050	1	1300	2620	2620	1860	–
Bogie di traslazione Driven bogie Boggie motorisèe Balancin de traslaciòn		4	1160	700	600	700	2800	
Blocco zavorra di base Base ballast block Lest de base Blaque de lastre		5x5	2	5300	1000	600	7300	14600
		6x6	2	6400	1200	600	10600	21200
		5x5	–	4100	1600	300	3500	–
		6x6	–	4800	2000	300	5070	–
Corsoio di montaggio Climbing cage Cage de montage Jaula de montaje		SK1700	1	8300	2600	2500	6000	–
		SN2050	1	8300	2900	2700	6700	–

GRU IN CAVEDIO – TELESCOPAGE SUR DALLES – CLIMBING CRANE – KLETTERKRANE IM GEBAUDE

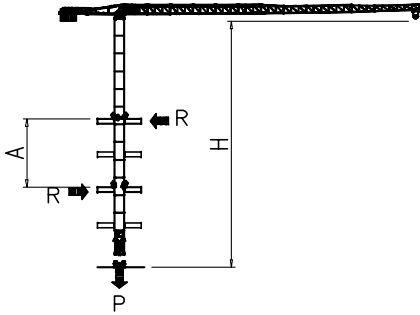

SN2050	H (m)	A (m)	R (t)	P (t)
	9	9	45.3	
	10	10	42	
	11	11	39.3	
	12	12	37	
	13	13	35	
	14	14	33.4	
	15	15	32	
	16	16	30.7	
	17	17	29.6	
	18	18	28.6	
Apertura passaggio gru Opening for crane passing 	19	19	27.8	
	20	20	27	

\* SOPRALZO IDRAULICO – TELESCOPABLE – EXTERNAL CLIMBING – KLETTERKRANE

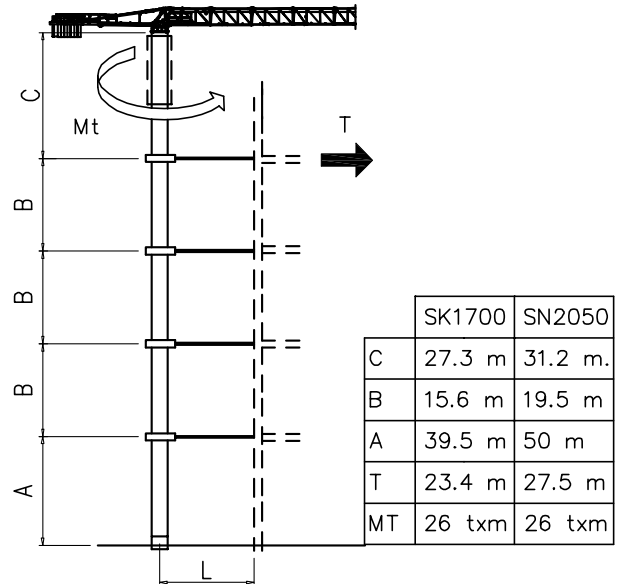
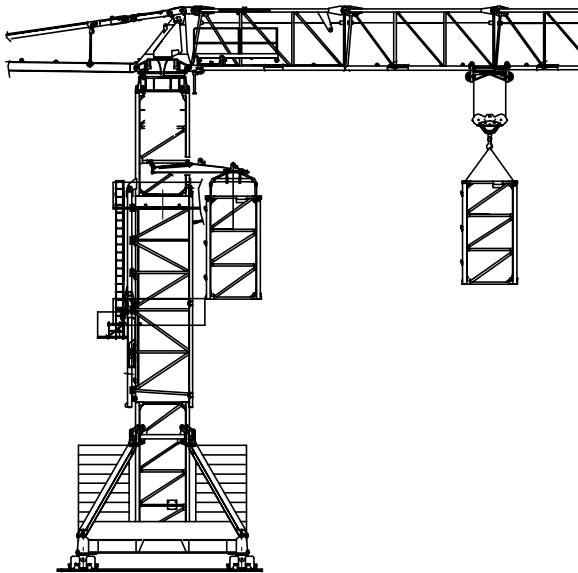

Montaggio – Montage – Erection – Montage – Montaje – Montagem

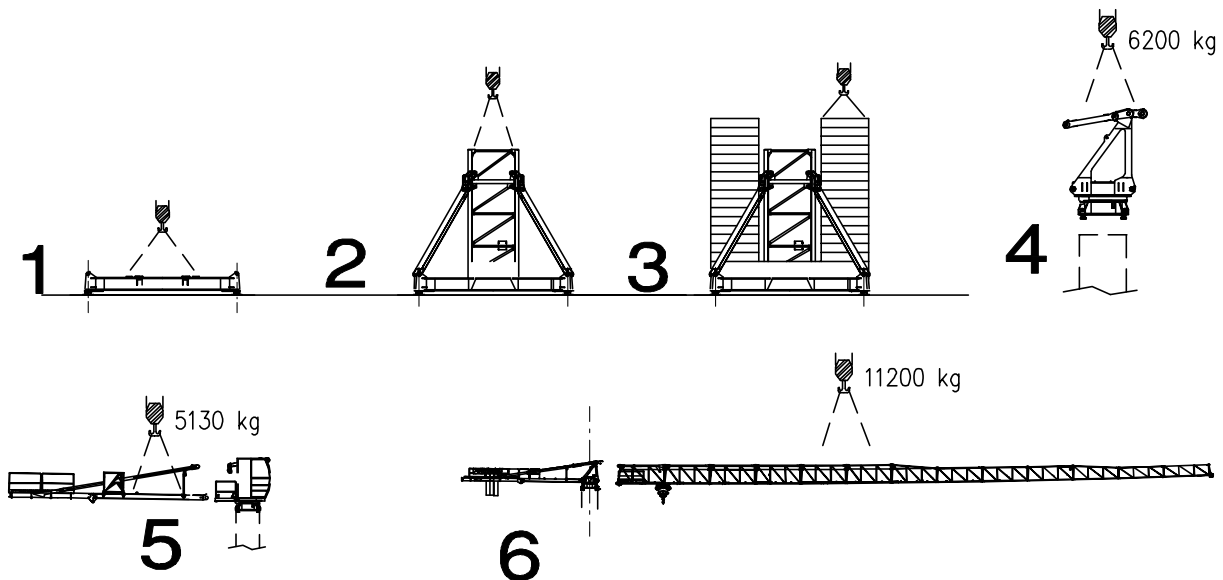

Sollevamento V25.60 Hoisting Levage Heben Elevaciòn Elevaçao														V25.60 18.4 kW 37 kVA  172 m
	m/min	7	18	28	42	56	65	3.5	9	14	21	28	32.5	
	t	3	3	3	2.25	1.5	0.9	6	6	6	4.5	3	1.8	

Sollevamento V33.90 Hoisting Levage Heben Elevaciòn Elevaçao														V33.90 22 kW 47 kVA  380 m
	m/min	3	18	34	54	70	90	1.5	9	17	27	35	45	
	t	3	3	3	1.8	1.3	0.5	6	6	6	3.6	2.6	1	

Carrello Trolleying Distribution Katzfahren Distribuciòn Distribuiçao			0 → 80	m/min	3 kW	Potenza elettrica necessaria Puissance électrique nécessaire Necessary electric power Anschlusswert – Potencia
Rotazione Slewing Orientation Schwenken Orientaciòn Rotaçao			0 → 0,9	giri/min tr/min rp/min	4.4 kW @ 1200rpm n° 2 x 2.2 kW	
Traslazione Travelling Translation Kranfahren Traslaciòn Traslaçao			0 → 20	m/min	3.7 kW	

Rete elettrica – Réseau – Mains supply – Netzstrom – Red – Rede electrica	400V – 50 Hz
---	--------------

**AFM Gru** FMgru s.r.l.  
via Emilia 11-29010 Pontenure PC ITALY  
tel. 0523/510446 ric.aut. fax 0523/510365  
www.fmgru.it e-mail: info@fmgru.com

FEM 1.001  
2000/14/CE



Documento commerciale non contrattuale  
Per tutte le informazioni tecniche riferirsi  
alle corrispondenti istruzioni

Unverbindliches Vertriebsdokument.  
Für technische Informationen, siehe die  
entsprechenden Anweisungen.

This commercial document is not legally  
binding. For any technical information, please  
refer to the corresponding instructions.

Documento comercial non contractual  
Para cuatquities informacìon tecnica,  
ver la noticia correspondiente.

Code: 15/CA37T45A0		
Ed.	Data	Rev Data
1	25.03.01	2
		25.03.10